



**B 400 H**

LA BARREDORA VIAL QUE FACILITA TU TRABAJO  
 THE URBAN SWEEPER THAT MAKES YOUR WORK EASIER  
 KEHRMASCHINE FÜR DEN KOMMUNALBEREICH WELCHE DAS ARBEITEN EINFACH MACHT !  
 LA BALAYEUSE QUI FACILITE VOTRE TRAVAIL



**AUSA Center, S.L.U.**  
 Ctra. de Vic Km 2.8  
 08243 Manresa - Barcelona  
 Tel.: +34 93 874 73 11  
 Pol. Ind. Coslada - Marconi 15-17  
 28823 Coslada - MADRID  
 Tel.: +34 91 669 00 06  
 ausa@ausa.com · www.ausa.com



**AUSA France** Z.I. Saint Charles - Rue de Zürich, 66000 PERPIGNAN - Tel: +33 (0) 4 68 54 38 97 - E-mail: ausa.france@ausa.com  
**AUSA Deutschland** Tel.: +49 (0) 2384 9889905 - E-mail: ausa.deutschland@ausa.com  
**AUSA UK** Tel.: +44 (0) 7970639988 - E-mail: ausa.uk@ausa.com  
**AUSA Brasil** Avenida Belizario Ramos 2276 - Lages - SC, 88506-000 - Tel.: +55 11 9 8786 6014 - E-mail: ausa.brasil@ausa.com  
**AUSA U.S. CORP.** Tel.: +1 (917) 328 0770 - E-mail: ausa.us@ausa.com  
**AUSA Beijing Rep. Office** Room 403, Moma Building, N.199 - Chaoyang bei road, Chaoyang District - 100026 BEIJING  
 Tel.: +86 10 8598 7386 - E-mail: ausa.china@ausa.com

**B 400 H**



www.ausa.com

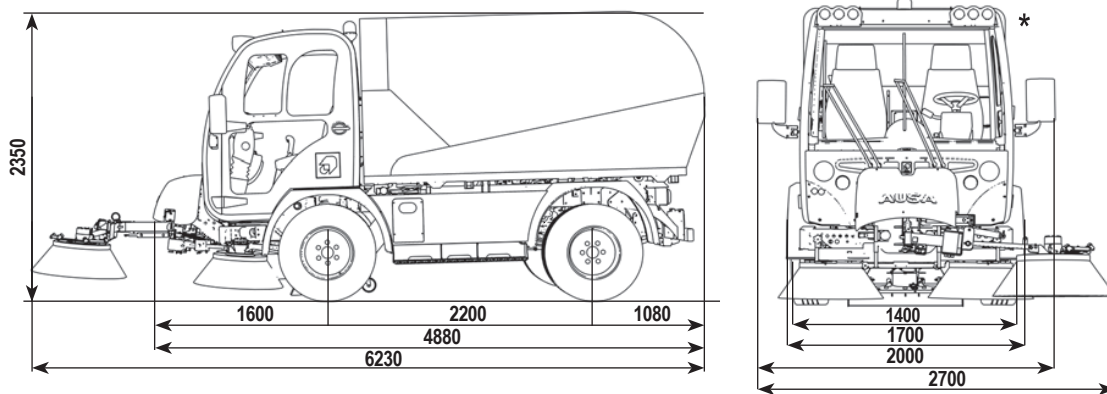

**TECHNICAL SPECIFICATIONS**

		<b>B 400 H x2 / x4</b>
Waste hopper ALUMINIUM	Capacity	4 m <sup>3</sup>
Water tank INOX	Capacity	500 l (INOX)
Sweeping system	Vacuum power	13000 m <sup>3</sup> /h
	Brooms	2 standard brooms of Ø850 mm / 3rd optional broom Ø850 mm
	Sweeping path width	2000mm / 2700mm with 3rd optional broom
Vacuum nozzle		Nozzle width 800 mm / Adjustable gate / Stainless steel
Engine	Make	VOLKSWAGEN
	Type	2.01 TDI
	Emission regulations	EURO 5
	Power (Kw - Cv)	75-102 (3000 rpm)
	N. of cylinders	4
	Cooling	Liquid
	Fuel	Diesel
Tank capacity (l)	Fuel	85
Unloading system	Hopper discharge angle	50°
	Backwards movement	200 mm
	Hopper dump height	1540 mm
Transmission		2 hydrostatic speeds + 2 mechanical speeds
	Maximum speed	Limited to 40 km/h or 25 km/h / Optional 62 Km/h available in certain countries
	Traction	4x2 rear locking differential on demand
Gradient negotiable (with full load)		28%
Brakes	Service	Power-assisted hydraulic master cylinder, disc on front wheels and drum brake on rear wheels Optional ABS + EBD (Standard at 62 km/h)
	Parking	Negative parking brake, hydraulically released Hydraulically power-assisted steering
Steering		Hydraulically power-assisted steering
Suspension		Front suspension helicoidal spring & hydraulic damper Rear suspension parabolic leaf spring & Hydraulic damper
Weight (Kg) *	Unloaded weight	4680 - 4740 (2490 front axle ; 2200 rear axle)
	Gross weight	6400 (2650 front axle ; 3750 rear axle)

**STANDARD EQUIPMENT**

Front brooms (2) broom side-shift (+/- 200mm)
Closed cabin with heating
Doors with excellent visibility
Electronic boost of rpm engine
Monitor with 2 cameras: suction nozzle / backwards visibility
Quick "LINK"® coupling / uncoupling fast system of optional interchangeable attachments for the sweeper
Water coupling STORZ 2"
Water couplings Barcelona 45 / 70
Hose 5m
Waste tank inspection window
Seat with suspension
Rotating beacon with telescopic support of 450mm length
Electrically adjustable rear mirrors with heater
Approved lightning system with electrical settings on head lamps
Wheel wrench
Wiring for transceiver set
Radio-CD & MP3 + Bluetooth
Front plate for attachments
Right hand drive for better sweeping visibility

**OPTIONAL EQUIPMENT**

Sweeping water recirculation system
3rd broom with long reaches (850mm)
Auxiliary manual wander hose reaching up to 5 m / Ø160 mm
High pressure water jet spray lance (150 bar / hose length 15m / possibility use of detergent)
High pressure water jet spray lance with hose reel (150 bar / hose length 16m / possibility use of detergent)
Standard support legs for taking-off the sweeping equipment
Air conditioning
Tacograph
Seat with pneumatic suspension
Towing hitch ball (50 mm) with electric socket (13 pins)
Towing hitch "Rockinger" with electric socket (13 pins)
Automatic lubrication system
62km/h with ABS + EBD and 2 mechanical speed
ABS + EBD (on 40km/h version)
4x4 FULL GRIP® System and rear locking on demand

\* Load or dimension data may change due to optional equipment

AUSA reserves the right to make any changes in the specifications without prior notice.