

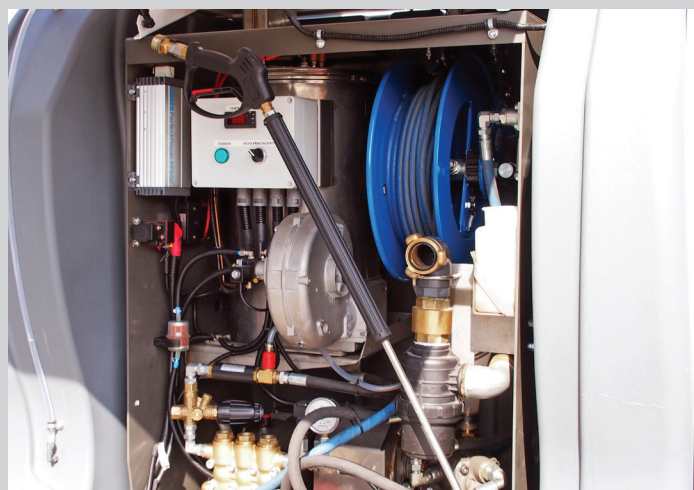

**WH 200 H**

**EQUIPO HIDROLIMPIADOR DE ALTAS PRESTACIONES PARA LIMPIEZA URBANA  
HIGH PERFORMANCE WATERCLEANER EQUIPEMENT FOR URBAN CLEANING  
HOCHLEISTUNGS-AUSSTATTUNG WASSERREINIGUNG FÜR DIE KOMMUNALREINIGUNG  
LAVEUSE DE VOIRIE A HAUT RENDEMENT**



**AUSA Center, S.L.**  
Ctra. de Vic Km 2.8  
08243 Manresa  
BARCELONA (ESPAÑA)  
Tel.: +34 93 874 73 11  
E-mail: [ausa@ausa.com](mailto:ausa@ausa.com)  
[www.ausa.com](http://www.ausa.com)

**AUSA Madrid** Pol. Ind. Coslada - C. Marconi 15-17, 28823 Coslada - MADRID (ESPAÑA) - Tel.: +34 91 669 00 06 - E-mail: [ausa.madrid@ausa.com](mailto:ausa.madrid@ausa.com)  
**AUSA France** Z.I. Saint Charles - Rue de Zürich, 66000 PERPIGNAN (FRANCE) - Tel: +33 (0) 4 68 54 38 97 - E-mail: [ausa.france@ausa.com](mailto:ausa.france@ausa.com)  
**AUSA Deutschland** Tel.: +49 (0) 2384 9889905 - E-mail: [ausa.deutschland@ausa.com](mailto:ausa.deutschland@ausa.com)  
**AUSA UK** Tel.: +44 (0) 7970639988 - E-mail: [ausa.uk@ausa.com](mailto:ausa.uk@ausa.com)  
**AUSA Brasil** Avenida Belizario Ramos 2276 - Lages - SC, 88506-000 (BRASIL) - Tel.: +55 11 9 8786 6014 - E-mail: [ausa.brasil@ausa.com](mailto:ausa.brasil@ausa.com)  
**AUSAMéxico** Calzada Vallejo 725 Del. Gustavo A. Madero - 07750 México D.F. (MÉXICO) - Tel.: +52 (55) 21669276 - E-mail: [ausa.mexico@ausa.com](mailto:ausa.mexico@ausa.com)  
**AUSA U.S. CORP.** Tel.: +1 (917) 328 0770 - E-mail: [ausa.us@ausa.com](mailto:ausa.us@ausa.com)  
**AUSA Beijing Rep. Office** Room 403, Moma Building, N.199 - Chaoyang bei road, Chaoyang District - 100026 BEIJING (CHINA)  
Tel.: +86 10 8598 7386 - E-mail: [ausa.china@ausa.com](mailto:ausa.china@ausa.com)



# WH 200 H



www.ausa.com

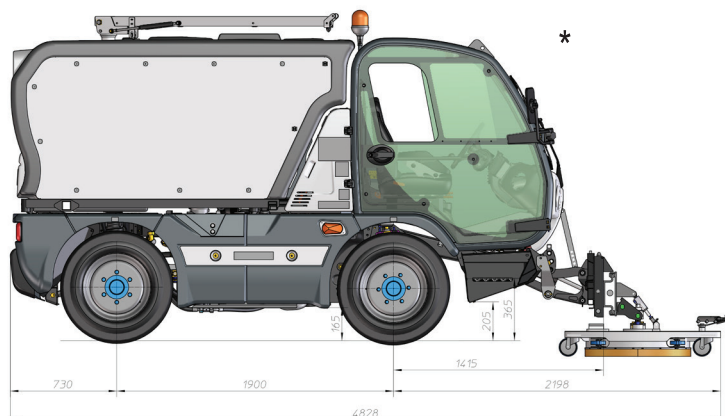
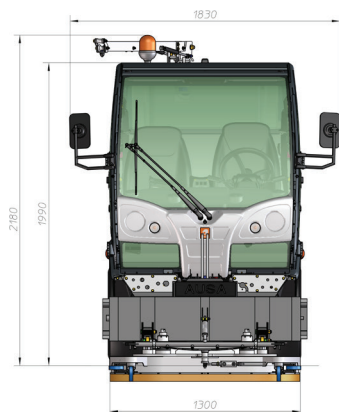

## TECHNICAL SPECIFICATIONS

		WH 200 H			
		4x2x2	4x2x4	4x4x4	
<b>Drive-line configuration</b>		2 wheel steering and 2 wheel drive	4 wheel steering and 2 wheel drive	4 wheel steering and 4 wheel drive	
<b>Cleaning systems</b>	Tank water capacity	2000 l			
	Material	HDPE Rotomoulding			
	High pressure pump	21 litre/minute at 300 bar			
	Washing device	Washer steam cupola			
	Water heater	T. max. 75°C			
<b>Weight</b>	Unloaded weight *	2110 - 2455 Kg			
<b>Engine</b>	Make	VOLKSWAGEN			
	Type	2.0 TDI			
	Emissions	Euro 5			
	Power (Kw - CV)	75 -102 (3000 rpm)			
	N. Of Cylinders	4			
	Cooling system	Liquid with variable speed fan and auto cleaning system			
	Fuel	Diesel			
	Tank capacity	60 l			
	<b>Transmission</b>	Type	Hydrostatic Rexroth with 2 wheel radial motors on rear axle	Permanent 4WD and 4 wheel steering flow track	
		Max speed	40 km/h		
Max working speed		25 km/h			
Gradient negotiable		27% at full load (30% at 4500 Kg)		37% at full load	
<b>Brakes</b>	Service	Servo assisted brake, disk brake on front wheels and drum brakes on rear wheels		Servo assisted brake. Drum brakes on four wheels	
	Parking	Negative parking brake, hydraulically released			
<b>Steering</b>	Type	Orbitrol hydraulic steering			
	Modes	Front	Front / Front + Rear	Front / Front + Rear	
<b>External turning radius</b>		3623 mm	2762 mm	2762 mm	
<b>Suspension</b>	Front	Hydraulic damper & helicoidal spring			
	Rear	Hydraulic damper, helicoidal spring & anti roll bar			
<b>Wheels</b>	Front / Rear	225 / 70 R15			
<b>Auxiliary hydraulic circuit</b>	Hydraulic Pump	Triple gear pump - 22cc - 16cc - 11cc			
	Front Quick Couplings	3 quick-attach and independent hydraulic couplings (5 l/min) and 1 quick-attach hydraulic coupling (50 l/min)			
	Rear Quick Couplings	1 quick-attach and independent hydraulic couplings (5 l/min) - 1 quick-attach and independent hydraulic couplings (20 l/min) - 1 quick-attach and independent hydraulic couplings (50 l/min)			
<b>STANDARD EQUIPEMENT</b>		Front plate tool-carrier Link® System			
		Driver position on the left side of the vehicle			
		Driver seat with mechanical suspension			
		Passenger seat			
		Steering wheel with regulation on height and depth			
		High capacity cabin heater			
		Electronic control for the speed of the engine			
		Electronic control for the travel speed			
		Radio pre installation			
		Quick coupling Link® system			
		AUSA fuel saving system (A.F.S.) in long distance travel at high speed			
		Front plate tool-carrier Link® System - For AUSA attachments coupling bracket			
		Front plate tool-carrier Link® System - Triangular coupling bracket			
		Driver position on the right side of the vehicle			
		Driving seat with neumatic suspension			
	Electrically and adjustable rear mirrors with heater.				
	Working LED lights on the top of the cabin				
	Automatic grease system				
	Air conditioning				
	Radio-CD & MP3 + Bluetooth				
	Towing hitch ( 50 mm ball & 13 pins) with electric socket				
	Towing capacity 750 kg without brake; 3.500 kg with brake				
	Extensible legs for attachments disassembly				
	Camera rear vision with display in cabin				
<b>OPTIONAL EQUIPEMENT</b>					